

# Blog #8, The Frax Repair

## by Dudley Giberson

In 1999 I built a new studio kiln we call “Quancy” after its obvious shape– maintenance shed inspiration. This is a great kiln design first developed by Dominick Labino, circa 1964<sup>1</sup>. It is an idea that I have used scaled up and scaled down. I built “Quancy” specifically for working with core vessel shapes as it had a specific floor configuration for holding clay cores on mandrels. The important thing is this is made of Fiber Blanket Insulation, a superb material for insulation but not for toughness. Figure 1 is a line drawing of the basic design. Figure 2, shows what the front lip looks after 25 years of hard use and the many times of getting bumped or touched. This is what we will try to fix.

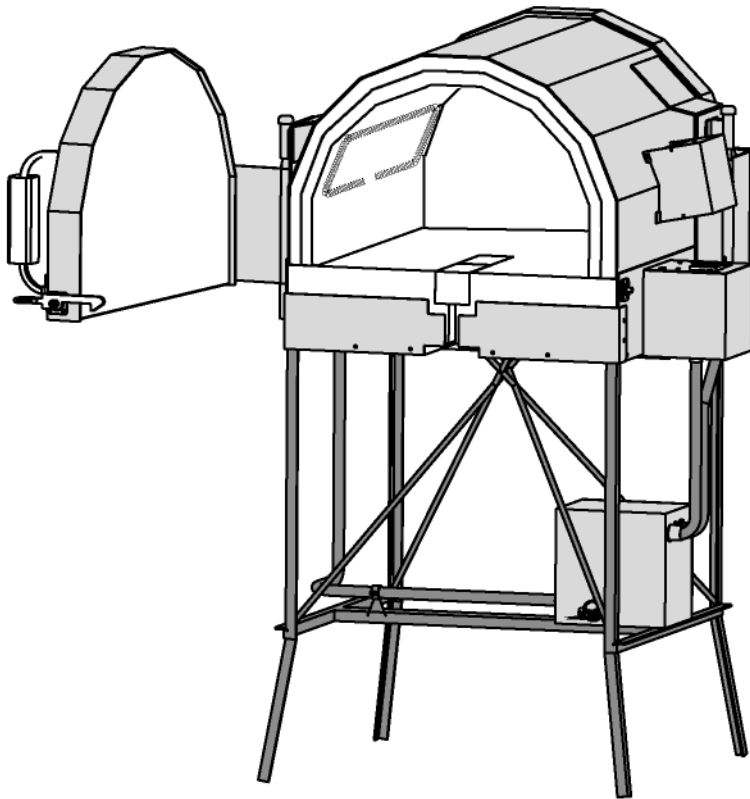

Fig. 1. The design as planned in 1999 when it was used for core vessel research.

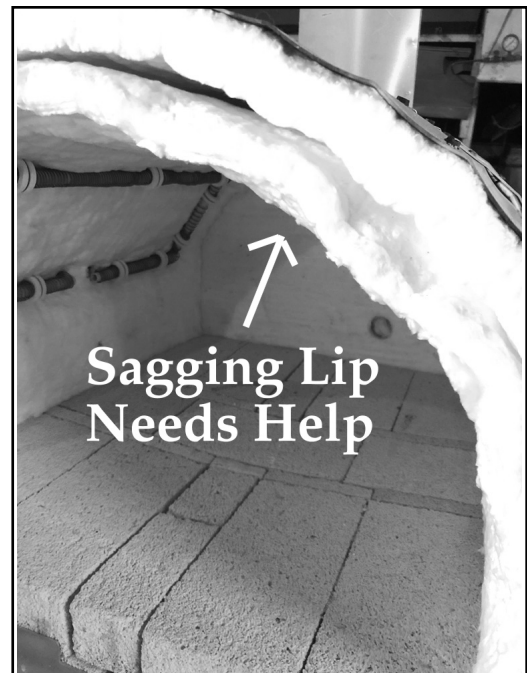
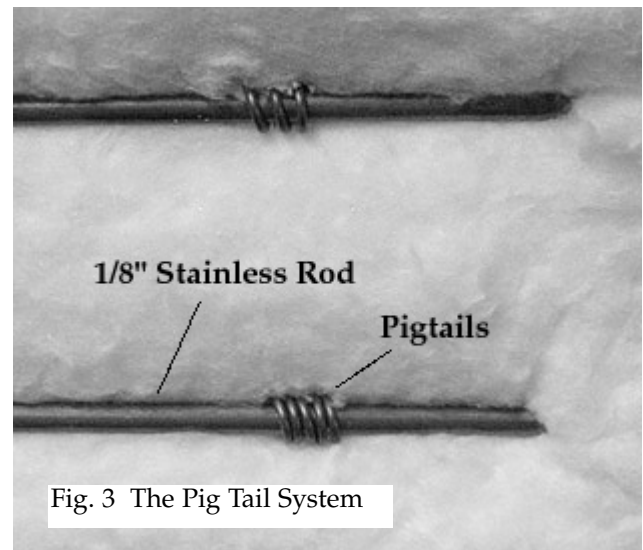

Fig. 2. Blanket insulation is terrific insulation but it does have quirky problems– for one it shrinks over time/and with high temperatures. In my case it has been used hard for 25 years. We need to make a simple repair. The front crown/door area needs some help.

I have a simple solution for attaching Frax that has proved to be effective. I call it the "PIG TAIL SYSTEM." It has a couple components: A stainless 1/8" TIG welding rod (308L) which does the holding and pig tail tie downs made of 17 gauge Nichrome wire which hold the stainless rod in place. I invented this system for holding frax in position on my production bead kiln doors. It passes the ten thousand hour test as there are a lot of them out there and they do not fail. In Fig. 3 we see this imaged.



## We start by making a handful of pigtails:

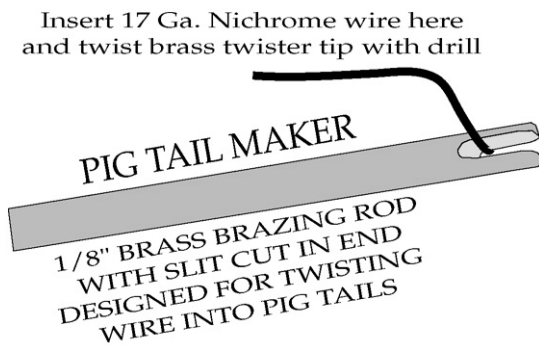

Fig. 4 The Pig Tail Mandrel

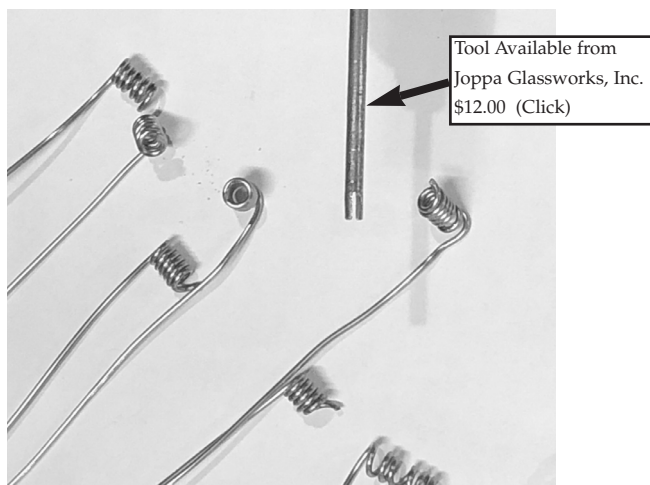
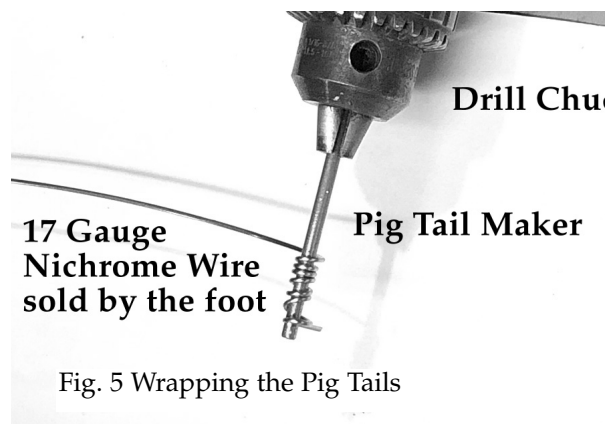

Fig. 6 A small collection of Pig Tails

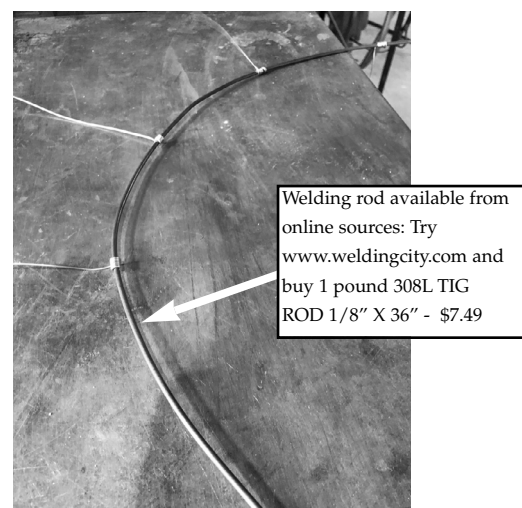
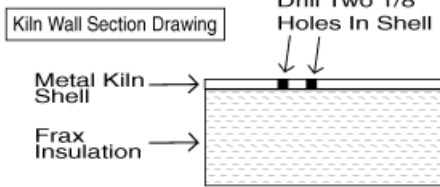

Fig. 7 The Stainless TIG Rod is bent to fit the Frax repair area. It is fitted with 5 Pig Tail wires.

# There are seven steps to the Pig Tail Installation Process:

## Step One



## Step Two

Place a sheet metal screw into one of the holes.

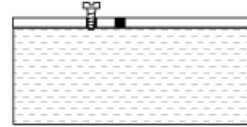

## Step Three

Install Pig Tail using a Fraxing Needle:  
Insert fraxing needle into the second hole and poke through the frax. This makes a path through the frax.

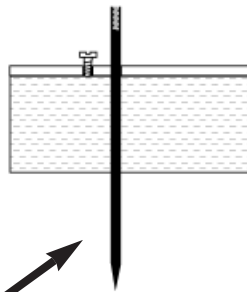

Brass Threading Needle Available  
Joppa Glassworks, Inc.  
Size is 6" x 1/8" Brass Rod with  
1/16" follow hole in rear of tool.  
Follow steps on this page to see  
how tool is used

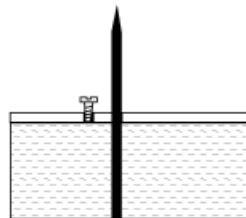

## Step Four

Reverse Needle

Reverse the needle and carefully wiggle it through the path in the frax through the hole in the sheet metal.

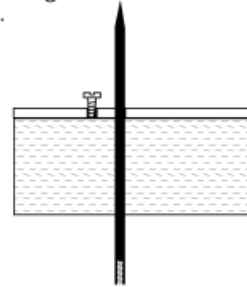

## Step Six

Gently Pull Up -  
Then loosely bend over wire end to keep it from going back down into the hole

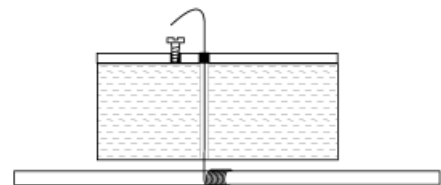

Step Five  
Put Wire End of Pig Tail  
in Butt End of Needle

Then Push  
UP



## Step Seven: The Finished Idea

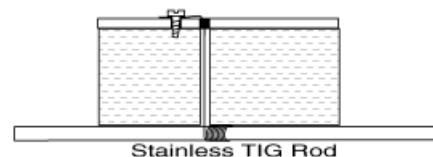

Stainless TIG Rod

Once all the Pig Tails are loosely installed pull out the slack and tighten the sheet metal screws to secure the final fit.



This is a very handsome install. Here, even though the Frax Holding Bar is close to the element, it does not pose a problem because frax is a decent electrical insulator. This addition has really improved the sturdiness of the door frame and frax layers. It makes this repair 100% successful. There is one caveat I would not use this for service over 1650°F. So I would say it is good for annealers, slumpers and casting kilns.

All tools needed for this repair business are available from Joppa Glassworks, Inc. Visit our web site and parts for sale page to go with this blog.

**This Blog is brought to you by Joppa Glassworks, Inc.**

**Visit our web site: [www.joppaglass.com](http://www.joppaglass.com)**

**We make Burners and Kiln Elements**

**Please email with any questions or comments to**

**[joppaglass@conknet.com](mailto:joppaglass@conknet.com)**